

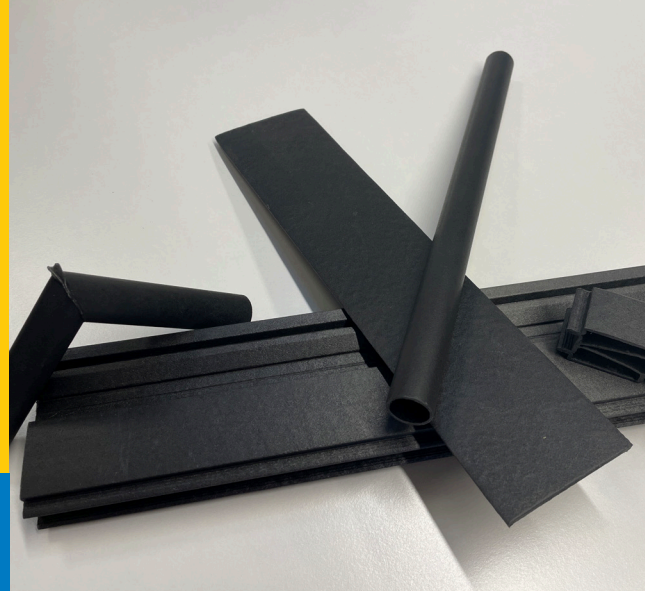

DISCOVER RIGICORE®

– THE FUTURE OF SUSTAINABLE
 HIGH-PERFORMANCE MATERIALS

This innovative RigiCore material incorporates up to 40% recycled carbon, making it a 100% recycled high-performance solution with superior strength and stiffness.



RigiCore® profiles, well-suited for building products. Primo's solutions are unique worldwide.

WHY CHOOSE RIGICORE®?

SUSTAINABILITY AT ITS BEST

By using post-use and post-industrial waste, RigiCore significantly reduces environmental impact while maintaining high quality.

HIGH STRENGTH AND STIFFNESS

RigiCore can be designed to substitute traditional materials, including aluminum, and with far less environmental cost. Thanks to its high strength and stiffness, it is a perfect choice for projects requiring durability and performance, all while reducing the environmental footprint.

LIGHTWEIGHT ADVANTAGE

With a density less than half that of aluminum, RigiCore offers weight-saving benefits, making it ideal for industries where reducing weight is crucial, without compromising on performance.

INLINE MACHINING

RigiCore can be extruded using in-line processes, unlike e.g. metal or pultruded profiles which requires multiple, separate processes (cutting, stamping, milling, and surface treatment). This streamlines production, cuts costs/hours for our customers, and reduces CO2 emissions associated with multiple manufacturing steps.

PROPERTIES	EN/ISO TEST METHOD	SI UNIT	TYPICAL VALUE
Density	1183	g/cm ₃	<1.27
E-modulus	527-2	MPa	~15,000
Tensile strength	527-2	MPa	~90
Charpy impact	ISO 179-1eU	kJ/m ²	~30
Elongation at break	527-2	%	~2
CO ₂ -footprint (GWP)	-	Kg CO ₂ e/kg	<1.17
Color	-	-	Carbon Fibre

**EXTRUDED PLASTIC
PROFILES COVER
A WIDE RANGE OF
FUNCTIONALITIES.**

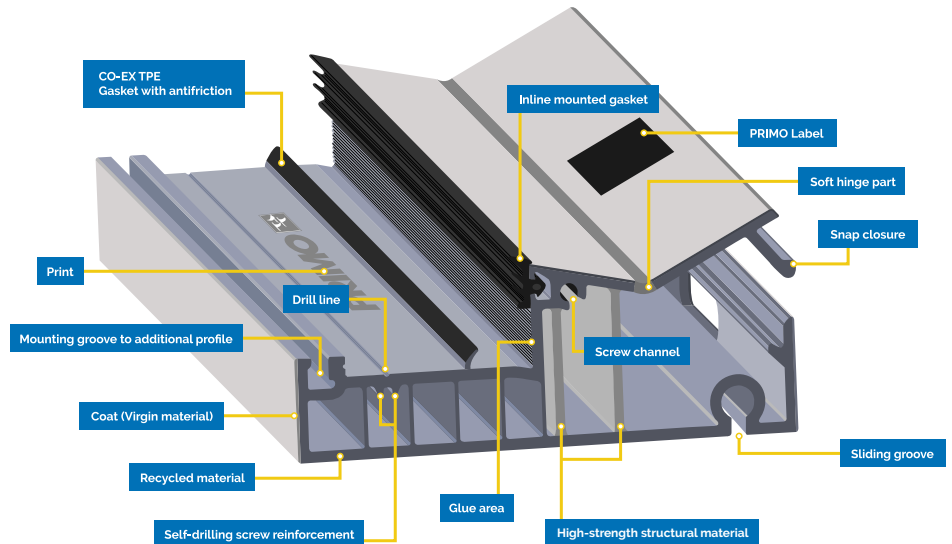

SUBSIDIARIES

ALABAMA, USA

PRIMO PROFILES ALABAMA LLC
7611 Lake Road South
Mobile AL 36605
USA

CHINA

PROFLEX PLASTIC TECHNOLOGY
(Zhuhai FTZ) Co. Ltd.
No. 41, Hongwan Free Trade Zone
Zhuhai, Guangdong, CHN 519030
sales@proflex.cn
www.proflex.cn

DENMARK

PRIMO DANMARK A/S
Jernbanegade 11
DK-6862 Tistrup
primo@primo.dk

FINLAND

OY PRIMO FINLAND AB
Tarhaajantie 2
FI-65380 Vaasa
primo.finland@primo.fi

GERMANY

PRIMO PROFILE GmbH
Otto-Porath-Platz 1
D-15831 Blankenfelde-Mahlow
info@primo-profile.de
Berlin/Hamburg

NETHERLANDS

PRIMO NETHERLANDS B.V.
Enitor Primo
Beatrixstraat 7
NL-9285 TV Buitenpost
infoenitor@primo.com

NORWAY

PRIMO NORGE AS
P.O.Box 2096
N-3255 Larvik
post@primo.no

POLAND

PRIMO PROFILE Sp. z o.o.
Ul. Chemiczna 2
PL 44-240 Żory
primoprofile@primo.com

SWEDEN

PRIMO SVERIGE AB
Box 4073
SE-514 12 Limmared
info@primo.se
Dalstorp/Limmared

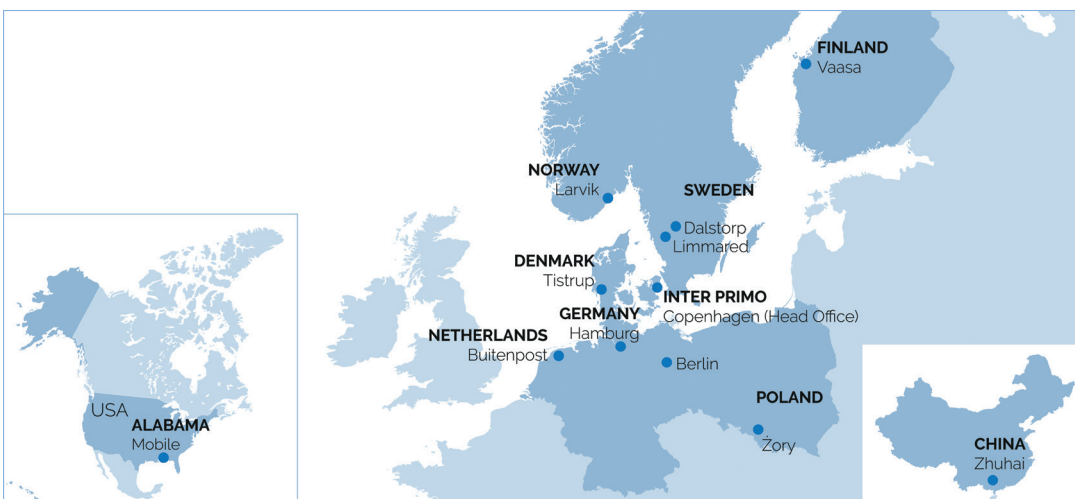

MOTHER COMPANY

INTER PRIMO A/S

Højbro Plads 6
DK-1200 København K
Denmark

www.primo.com